

UNCONTROLLED DOCUMENT

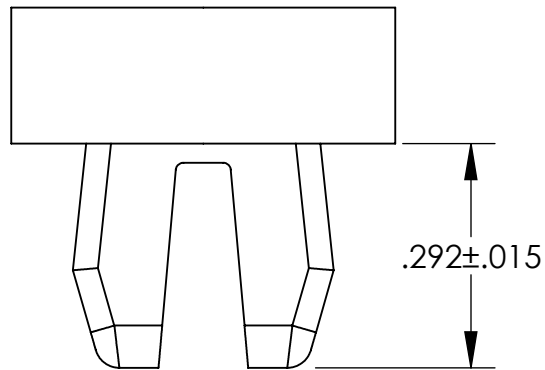
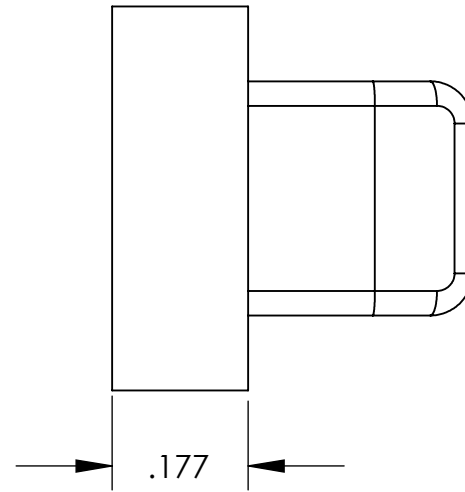
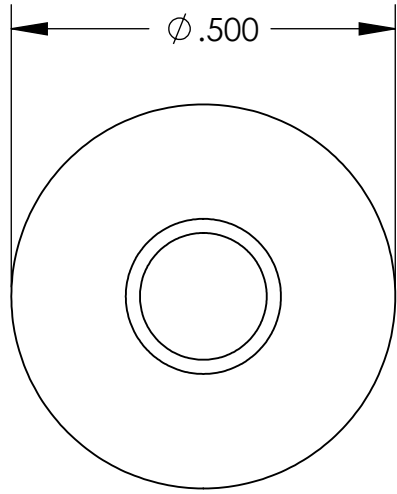

NOTES:
 HOLE SIZE .310 / .310
 PANEL THICKNESS RANGE .031 / .160
 SCREW SIZE #10

TOLERANCES UNLESS NOTED

- $\pm .005$ ON DIMENSIONS THRU .625
- $\pm .008$ ON DIMENSIONS .626 THRU 1.000
- $\pm .010$ ON DIMENSIONS 1.001 THRU 1.500
- $\pm .015$ ON DIMENSIONS LARGER THAN 1.500
- $\pm .015$ ON FRACTIONAL DIMENSIONS

WE RESERVE THE RIGHT
 TO DISCONTINUE ITEMS,
 CHANGE SPECIFICATIONS
 OR DESIGN AT ANY TIME
 WITHOUT NOTICE AND
 WITHOUT INCURRING
 ANY OBLIGATIONS

PROPERTY OF		
MICRO PLASTICS INC.		
CATALOG DRAWING ROUND HEAD GROMMET NUTS MICRO P/N 60SGN01143 DWG. # 60SGN01143 FILE SERVER\ENG\WEB		
MATERIAL:		NYLON 6/6
DATE	SCALE	DB
	4:1	