

SCREWS, BOLTS, & THREADED ROD

SECTION

II

SQUARE BASE WITH THREADED STUD **Molded in Natural Nylon 6/6**

Micro Plastics' nylon base with threaded stud has very high bond (VHB) white closed cell acrylic foam carrier with all purpose acrylic adhesive. Shear and peel strength is very high and material has very good solvent resistance. Acrylic adhesive has fair initial adhesion with gradual adhesion build up over 72 hours. Surface must be unified, dry, and free of contamination. Firm pressure must be applied to increase the cold flow and contact of the adhesive with the substrate. Parts can be purchased **without VHB adhesive foam**, just add **WOAF** to the end of part number.

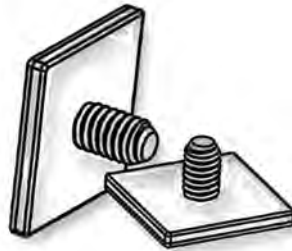
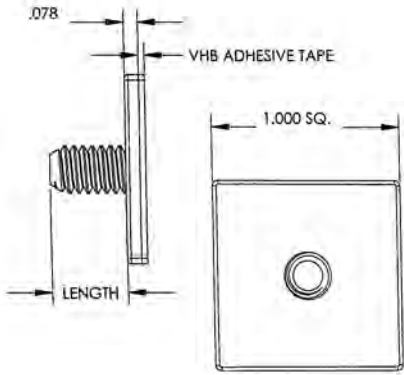

PART NUMBER	SCREW SIZE	THREAD	LENGTH
011032ABTS050	10	1032	1/2
011032ABTS075	10	1032	3/4
011032ABTS100	10	1032	1
012520ABTS050	1/4	1/4-20	1/2
012520ABTS075	1/4	1/4-20	3/4
012520ABTS100	1/4	1/4-20	1
013118ABTS050	5/16	5/16-18	1/2
013118ABTS075	5/16	5/16-18	3/4
013118ABTS100	5/16	5/16-18	1

THREADED STUDS **Molded in Natural Nylon 6/6**

Injection molded threaded studs with chamfer on both ends are available in several of the most popular sizes and lengths. Threaded studs are molded in natural Nylon 6/6 UL 94V2. These studs are resistant to most chemicals, electrically insulating, non magnetic, lightweight, low thermal conductivity, vibration and abrasion resistant.



PART NUMBER	SCREW SIZE	THREAD	LENGTH
3801032075SD	10	10-32	3/4
3801032100SD	10	10-32	1
3801032150SD	10	10-32	1 1/2
3801032200SD	10	10-32	2
3801032250SD	10	10-32	2 1/2
3825020075SD	1/4	1/4-20	3/4
3825020100SD	1/4	1/4-20	1
3825020150SD	1/4	1/4-20	1 1/2
3825020200SD	1/4	1/4-20	2
3825020250SD	1/4	1/4-20	2 1/2
3825020300SD	1/4	1/4-20	3
3831218100SD	5/16	5/16-18	1
3831218150SD	5/16	5/16-18	1 1/2
3831218200SD	5/16	5/16-18	2
3831218250SD	5/16	5/16-18	2 1/2
3831218300SD	5/16	5/16-18	3
3837516100SD	3/8	3/8-16	1
3837516150SD	3/8	3/8-16	1 1/2
3837516200SD	3/8	3/8-16	2
3837516250SD	3/8	3/8-16	2 1/2
3837516300SD	3/8	3/8-16	3
3837516400SD	3/8	3/8-16	4
3850013150SD	1/2	1/2-13	1 1/2
3850013200SD	1/2	1/2-13	2
3850013250SD	1/2	1/2-13	2 1/2
3850013300SD	1/2	1/2-13	3
3850013400SD	1/2	1/2-13	4
3850013500SD	1/2	1/2-13	5