

PANEL FASTENERS AND HOLE PLUGS

SECTION
VI

SHUTTER PINS

Molded in **TRANSLUCENT OFF WHITE Nylon 6/6**

Micro Plastics' SHUTTER PINS are used in the assembly of shutters. Molded in a Nylon 6/6 translucent off white color. Nylon 6/6/ is a material which has excellent wear properties, low coefficient of friction, good chemical resistance and will not rust. Part number 25USP-100 has a split head for greater retention.

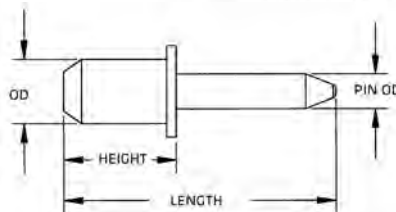
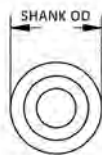
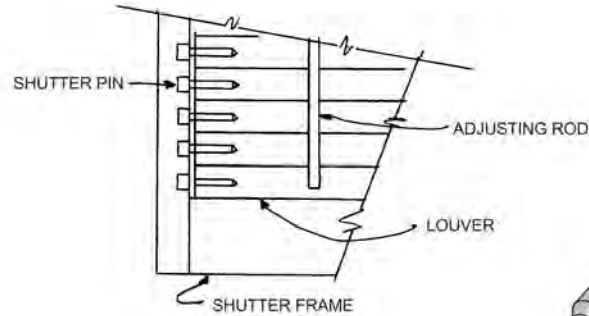
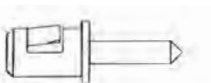
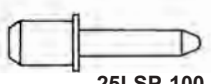
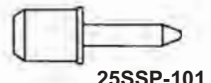
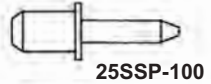
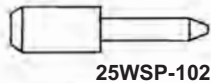
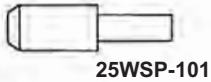
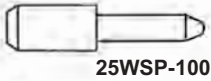

PART NUMBER	OD	PIN OD	HEIGHT	LENGTH	SHANK OD * REF
25WSP-100	.243 (6,17)	.140 (3,56)	31/64 (12,29)	1 1/16 (26,98)	
25WSP-101	.243 (6,17)	.140 (3,56)	31/64 (12,29)	7/8 (22,23)	
25WSP-102	.243 (6,17)	.117 (2,97)	31/64 (12,29)	1 1/16 (26,98)	
25SSP-100	.215 (5,46)	.117 (2,97)	3/8 (9,53)	29/32 (23,01)	19/64 (7,5)
25SSP-101	.280 (7,11)	.117 (2,97)	3/8 (9,53)	29/32 (23,01)	19/64 (7,5)
25LSP-100	.240 (6,10)	.140 (3,56)	3/8 (9,53)	1 1/32 (26,19)	19/64 (7,5)
25USP-100	.245 (6,22)	.120 (3,05)	13/32 (10,32)	55/64 (21,83)	5/16 (7,9)

SIGN FASTENER SYSTEM

Molded in **WHITE IMPACT MODIFIED Nylon 6/6**

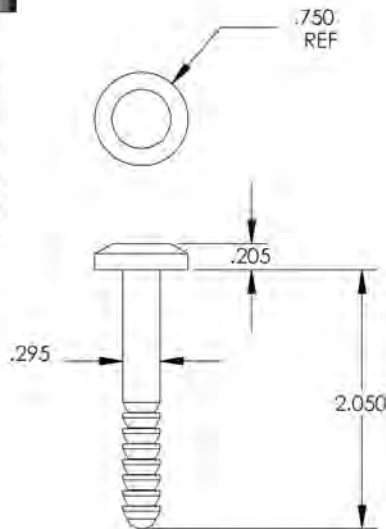

PIN

PART NUMBER
27RSFP001

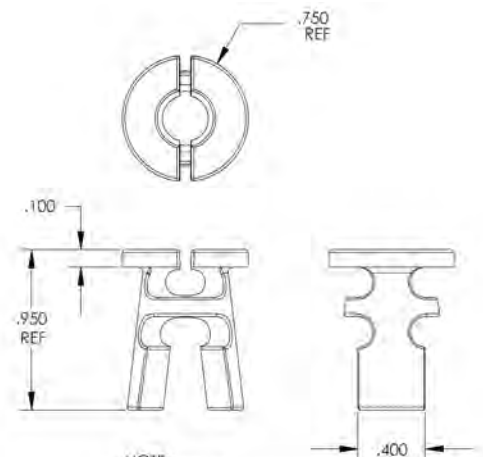

KEEPER

PART NUMBER
27RSFK001

NOTE:
HOLE SIZE: .312
PANEL RANGE: 1.000 - 1.750