

PANEL FASTENERS AND HOLE PLUGS

SECTION VI

POSTS AND SCREWS

Molded in **CLEAR** Polycarbonate

Molded in polycarbonate material. Stronger and more durable for industrial applications. Low cost, transparent fastener: female-threaded headed bushing and slotted-head machine screw.

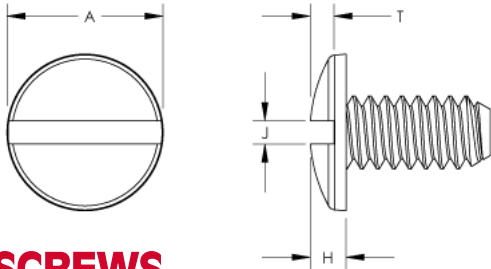

SCREWS

SCREW AND POST ARE SOLD SEPARATELY

ITEM NUMBER	SCREW SIZE	THREAD	A	H	J	T	LENGTH
010832POST025PC	8	832	.355	.093	.060	.062	1/4
010832POST037PC	8	832	.406	.093	.060	.062	3/8

Posts and Screws can also be purchased molded in Black or White Nylon.

Simple, effective, fast binding solution for a variety of applications, including;

- architectural drawings
- paper, scrapbooking
- swatch book fabric
- acrylic displays
- leather

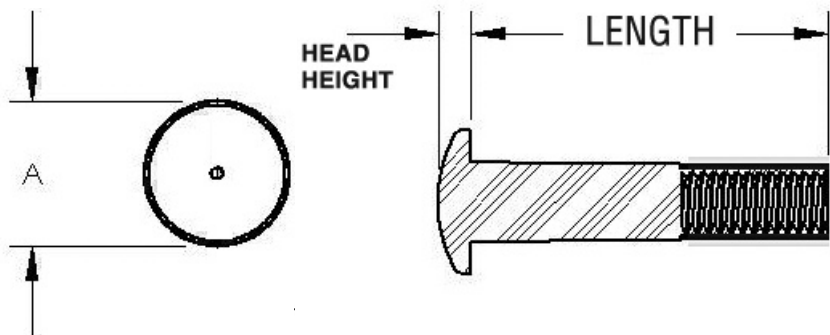

THREADED POSTS

ITEM NUMBER	THREAD	POST OUTSIDE DIA.	LENGTH	A	HEAD HEIGHT	SCREW LENGTH
27POST8320250	832	7/32	1/4	23/64	.093	1/4
27POST8320375	832	7/32	3/8	13/32	.093	3/8
27POST8320500	832	7/32	1/2	13/32	.093	3/8
27POST8320625	832	7/32	5/8	13/32	.093	3/8
27POST8320750	832	7/32	3/4	13/32	.093	3/8
27POST8320875	832	7/32	7/8	13/32	.093	3/8
27POST8321000	832	7/32	1	13/32	.093	3/8

