

Micro Plastics' Threaded Lampcord Bushings are molded in tough Black Heat Stabilized Nylon (Underwriters Laboratories Rated 94V2, Temperature Index 105°C). Micro Plastics has available from stock the most popular sizes of Threaded Lampcord Bushings. These bushings are designed to protect the electrical lampcord from the knife-edge of the threaded pipe used in light fixtures. They will easily thread onto standard lamp fixture 1/8 NPS and 1/4 NPS threaded ends. Micro Plastics' bushings will provide reliable, safe and insulated connections. Micro Plastics' has available from stock the most popular sizes of Threaded Lampcord Bushings.

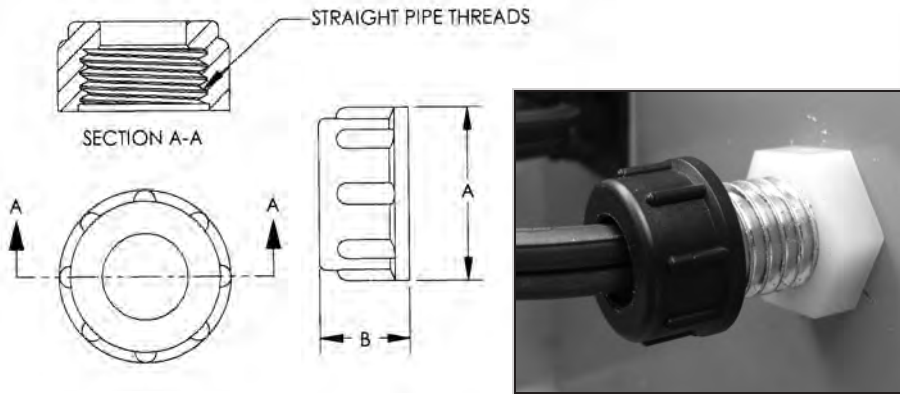

04MP0500TLB



04MP0375TLB



04MP0250TLB



04MP0125TLB



THREADED LAMPCORD BUSHINGS

Molded in **Black H.S. Nylon UL 94V2**

ITEM NUMBER	DESCRIPTION	A	B
04MP0125TLB	1/8 NPS	19/32" (15,08)	9/32" (7,14)
04MP0250TLB	1/4 NPS	23/32" (18,26)	3/8" (9,53)
04MP0375TLB	3/8 NPS	7/8" (22,23)	7/16" (11,11)
04MP0500TLB	1/2 NPS	1 1/16" (27,00)	3/8" (9,53)

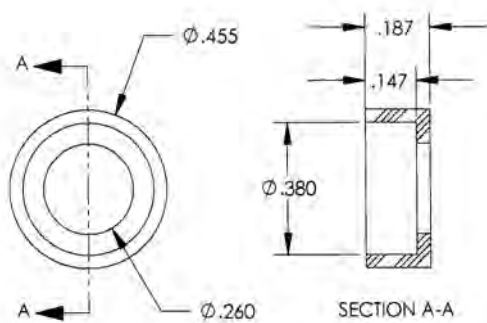

Micro Plastics' external lamp snap bushings are an economical approach to the protection of lampcord insulation, from the sharp and often burred ends of the standard threaded pipe used in lamp manufacture. Bushings are molded of Black Hi-density Polyethylene to allow flexibility for easy installation and durability for long lasting cord protection.

MINIMUM ORDER QUANTITY 1000 PCS.

LAMP SNAP BUSHING "external"

Molded in **Black High Density Polyethylene**



ITEM NUMBER	OD	ID	THICKNESS	COUNTER BORE DIAMETER	COUNTER BORE DEPTH
04MP0125SBOD	.455 (11,56)	.260 (6,60)	.187 (4,75)	.380 (9,65)	.147 (3,73)