

## CORD CLIP WITH PUSH MOUNT

Molded in **Natural Nylon 6/6**

Micro Plastics' cord clip is designed with a 5/8" (15,88) bundle diameter. To mount into a 1/4" (6,35) diameter hole. Cord clip is used to organize wires, cords and cables. Parts are molded in UL Recognized Nylon 6/6.

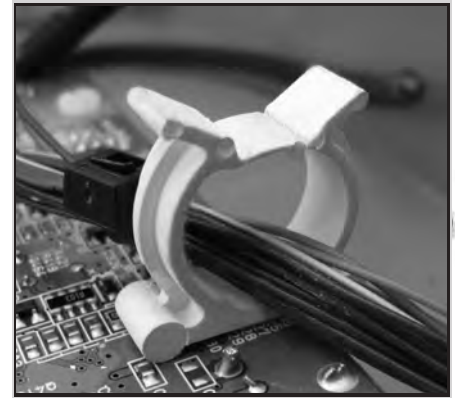
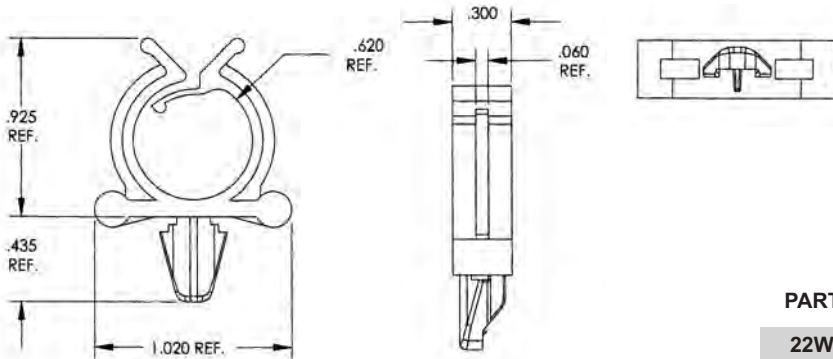

PART NUMBER	PANEL THICKNESS
22WCPM062250	1/16 (1,57)

## NYLON FUEL LINE CLIP

Molded in **Natural Nylon 6/6**

Micro Plastics' Fuel line Clip is molded Nylon 6/6 material that is resistant to oil and gasoline. Part snaps into a .031" to .079" panel thickness. Clip can be used for routing tubes and cables.

Material is rated UL94-V2

ITEM NUMBER
22FLC750830

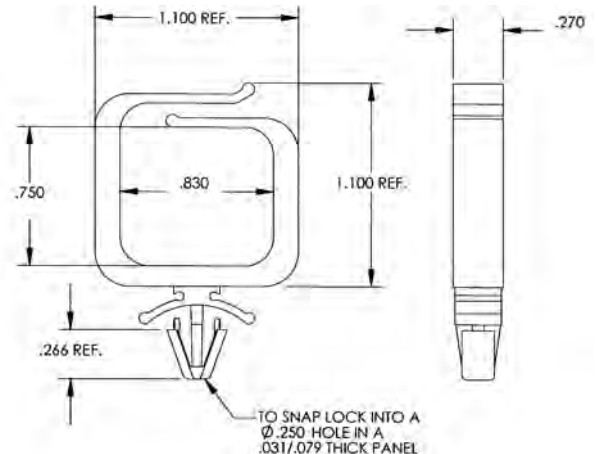

## CORD CLIP WITH ADHESIVE BASED MOUNT

Molded in **Black Nylon 6/6** NOTE: RELEASABLE TAB AVAILABLE UPON REQUEST

Micro Plastics' cord clip is designed with a 5/8" (15,88) bundle diameter. Cord clip is used to organize wires, cords and cables. Parts are molded in UL Recognized Black Nylon 6/6 with double coated foam tape for easy installation with out mounting screws.

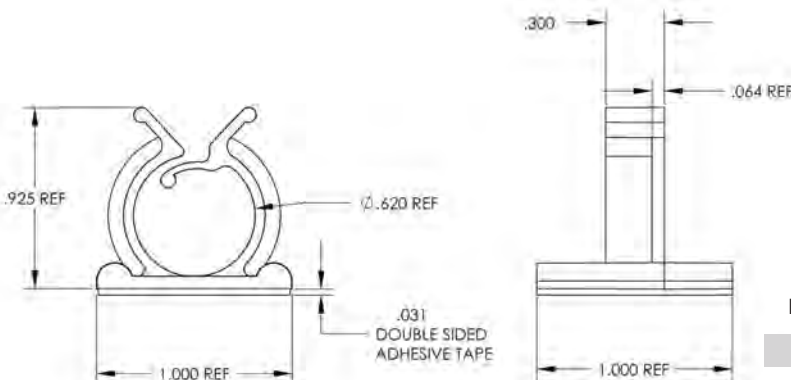

PART NUMBER	BUNDLE DIAMETER
22AWC00625	5/8" (15,88)