

NO.  
CODE  
C/M

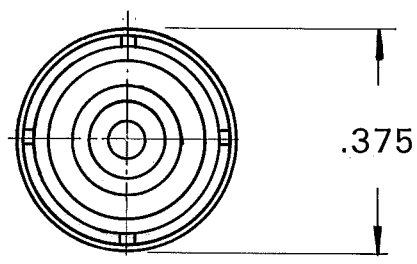
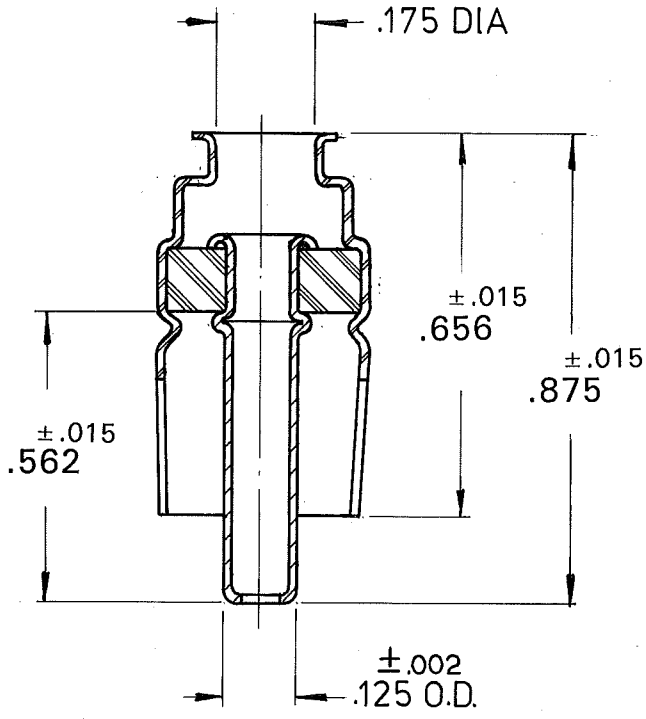

NOTE:  
SHELL: MAT'L - STEEL  
FINISH - ELECTRO TIN  
PIN : MAT'L - BRASS  
FINISH - NICKEL PL  
INSUL WASHER: .062 TH'K PHENOLIC

<b>KEYSTONE ELECTRONICS CORP.</b>			
ASTORIA, N.Y. 11105-2017			
PART NAME		PHONO PLUG	
MATERIAL		AS NOTED	
FINISH		DRAWN BY	DATE
AS NOTED		L.N.	2.14.83
		APPROVED	SCALE
		<i>[Signature]</i>	—
TOLERANCES		DWG. NO.	
FRACTIONAL ± .015		566	
DECIMAL ± .005 ANGULAR ± 1/4°			
UNLESS OTHERWISE NOTED			

10.7.96	CHANGE PER ECR 96-047	A
DATE	REVISION	ISSUE