

THIS DOCUMENT IS THE PROPERTY OF KEYSTONE ELECTRONICS CORP. AND SHALL NOT BE REPRODUCED, DISTRIBUTED OR USED AS A BASIS FOR MANUFACTURE WITHOUT PRIOR WRITTEN PERMISSION FROM KEYSTONE ELECTRONICS CORP.

**ACTUAL SIZE**

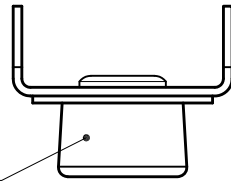

STUD P/N 261

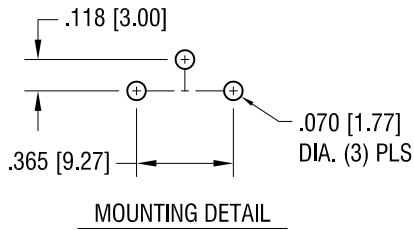
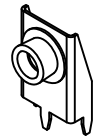
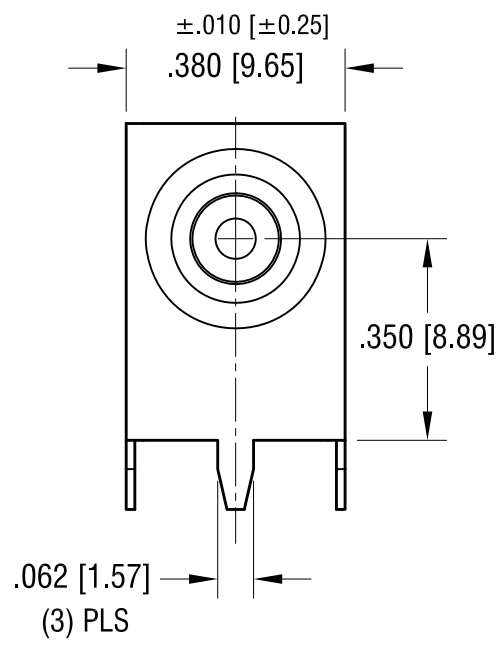
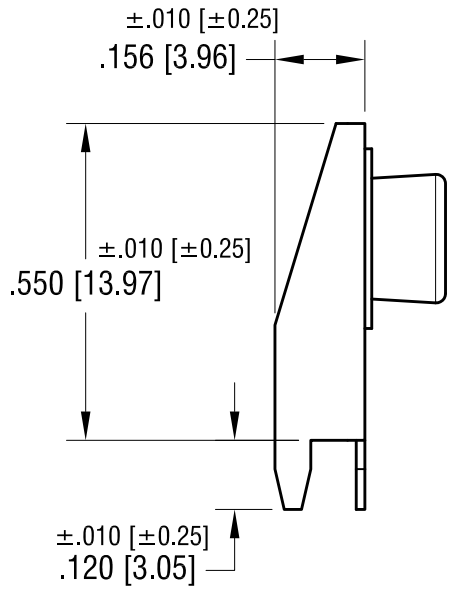

**NOTE:**

1. BASE - MAT'L: .015 [0.38] TH'K STEEL  
FINISH: MATTE TIN PLATE
2. STUD - MAT'L: STEEL  
FINISH: NICKEL PLATE

6.02.09	CHANGE AS PER ECN 09-041	A
DATE	DESCRIPTION	REV.

<b>KEYSTONE ELECTRONICS CORP.</b>			
www.keyelco.com • NEW HYDE PARK, NY 11040 • Tel (516) 328-7500			
PART NAME			
9 VOLT MALE PC SNAP-ON			
MATERIAL			
AS NOTED			
FINISH		DRN BY	DATE
AS NOTED		BOONE	12.08.98
		APP'D	SCALE
		LN	3X
TOLERANCES	INCH [MM]	CODE	DWG NO.
DECIMAL	± .005 [± 0.13]	C	593
ANGULAR	± 1°		
UNLESS OTHERWISE SPECIFIED			