

THIS DOCUMENT IS THE PROPERTY OF  
KEYSTONE ELECTRONICS CORP. AND  
SHALL NOT BE REPRODUCED, DISTRIBUTED  
OR USED AS A BASIS FOR MANUFACTURE  
WITHOUT PRIOR WRITTEN PERMISSION  
FROM KEYSTONE ELECTRONICS CORP.

ACTUAL SIZE

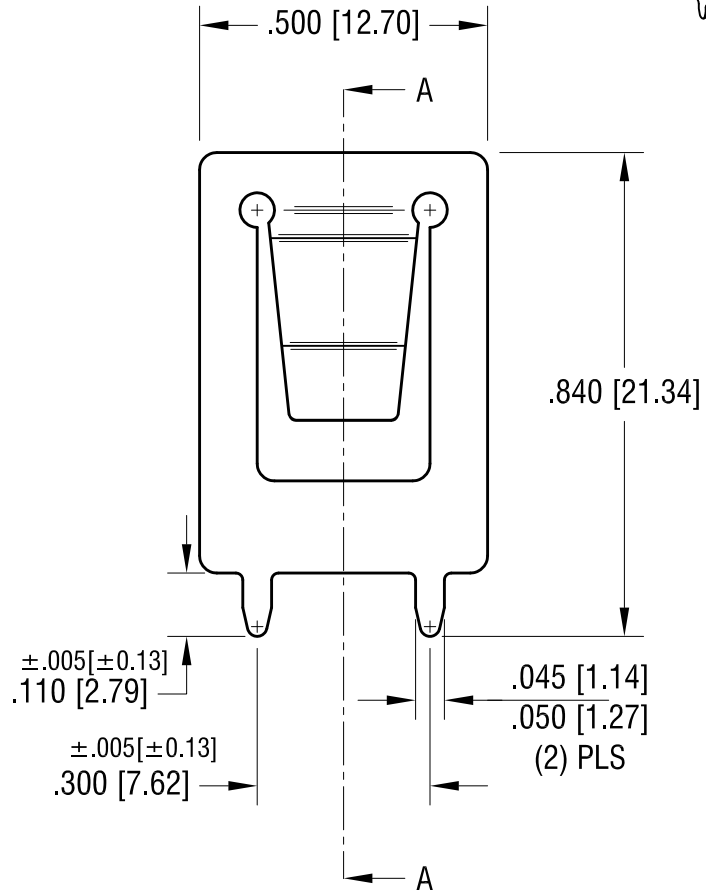
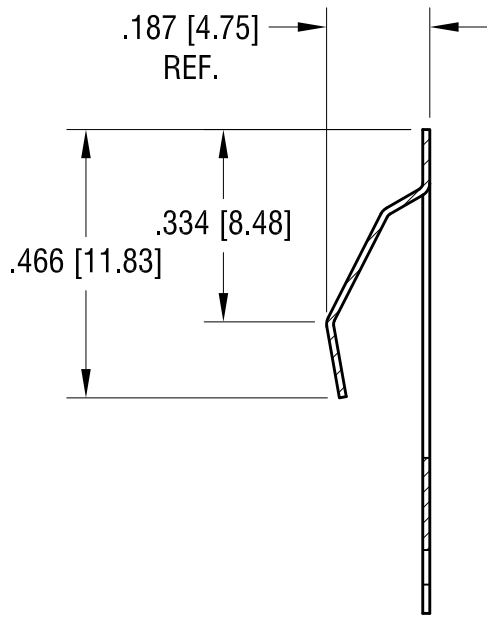
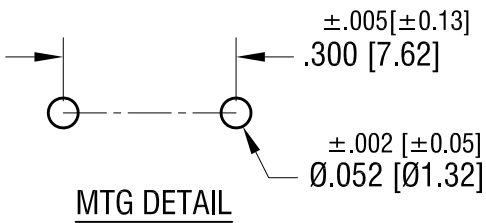

NOTE:

1. HEAT TREAT TO SPRING TEMPER

**KEYSTONE ELECTRONICS CORP.**

www.keyelco.com • NEW HYDE PARK, NY 11040 • Tel (516) 328-7500

PART NAME

PC BATTERY CONTACT

MATERIAL

.012 [0.30] TH'K ANNEALED SPRING STEEL

FINISH

NICKEL PLATE

DRN BY

BOONE

DATE

12.21.93

APP'D

RH

SCALE

3X

TOLERANCES

INCH [MM]

DECIMAL ±.010 [±0.25]

ANGULAR ± 1°  
UNLESS OTHERWISE SPECIFIED

CODE

C

DWG NO.

109-2

DATE

DESCRIPTION

REV.