

RECOMMENDED LAYOUT FOR 'AAA' BATTERY
USING (2) 230-1 CONTACTS

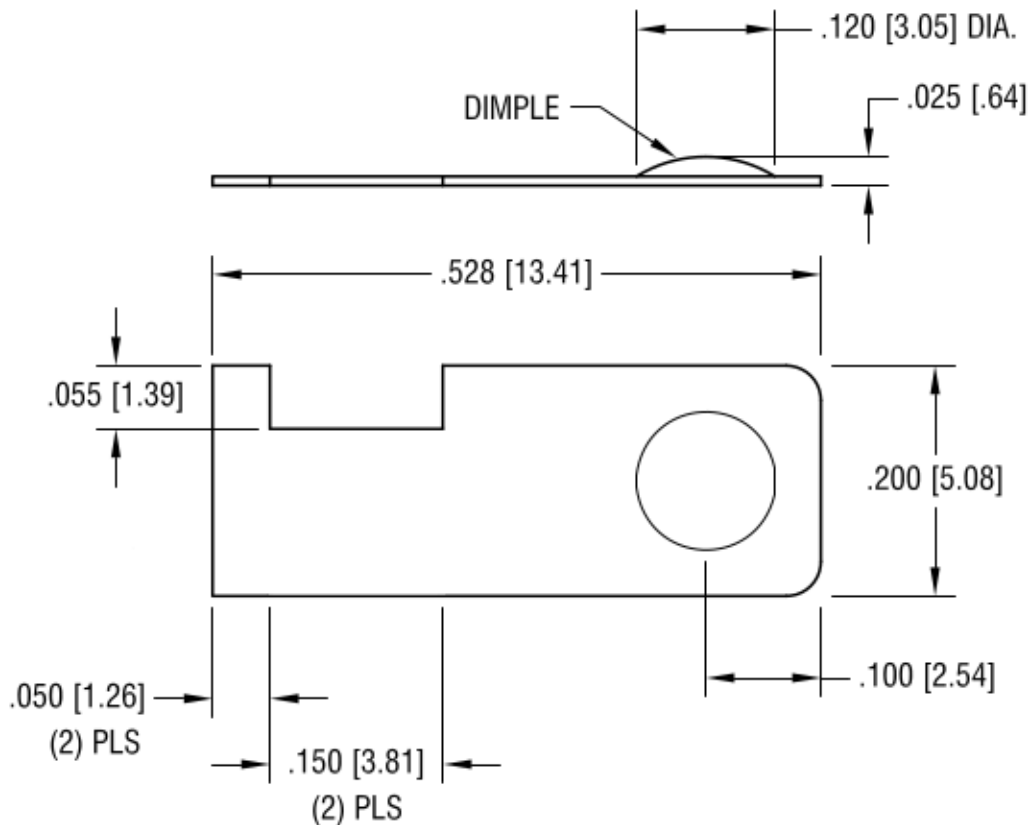
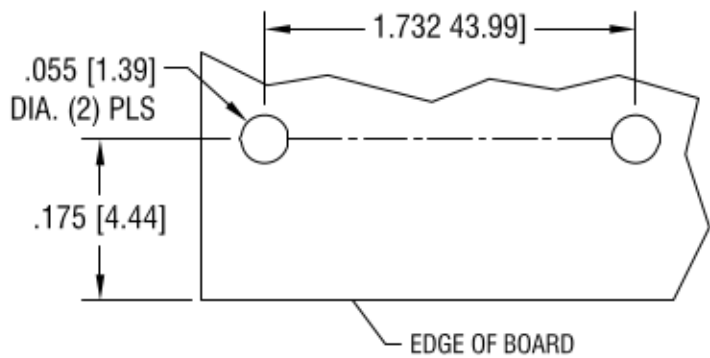

NOTE:

1. HEAT TREAT TO SPRING TEMPER

KEYSTONE ELECTRONICS CORP.

www.keyelco.com • NEW HYDE PARK, NY 11040 • Tel (516) 328-7500

PART NAME

PC BATTERY CONTACT

MATERIAL

.008 [0.20] TH'K ANNEALED SPRING STEEL

FINISH

TIN NICKEL PLATE

DRN BY

BOONE

DATE

4.18.02

APPD

LN

SCALE

6X

TOLERANCES

INCH [MM]
DECIMAL ± .005 [± 0.13]

CODE

C

ANGULAR ± 1°
UNLESS OTHERWISE SPECIFIED

DWG NO.

230

2.11.10

CHANGE AS PER ECN 10.013

B

9.9.04

CHANGE AS PER ECN 04-088

A

DATE

DESCRIPTION

REV.