

PCB Support - Dual Locking Barb - Nylon 66 - NATURAL

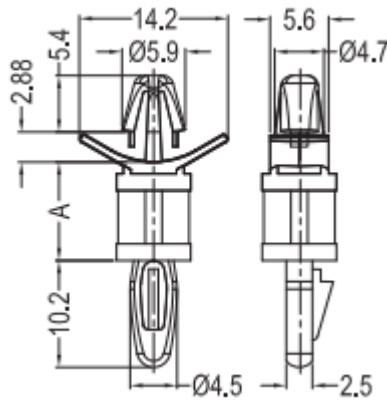

Part No.	A (mm)	PCB Thickness (mm)	PCB Mounting Hole (mm)	Chassis Thickness (mm)	Chassis Mounting Hole (mm)
M41528	6.4	1.57	4	0.79 - 1.98	4.75