

THIS DOCUMENT IS THE PROPERTY OF KEYSTONE ELECTRONICS CORP. AND SHALL NOT BE REPRODUCED, DISTRIBUTED OR USED AS A BASIS FOR MANUFACTURE WITHOUT PRIOR WRITTEN PERMISSION FROM KEYSTONE ELECTRONICS CORP.

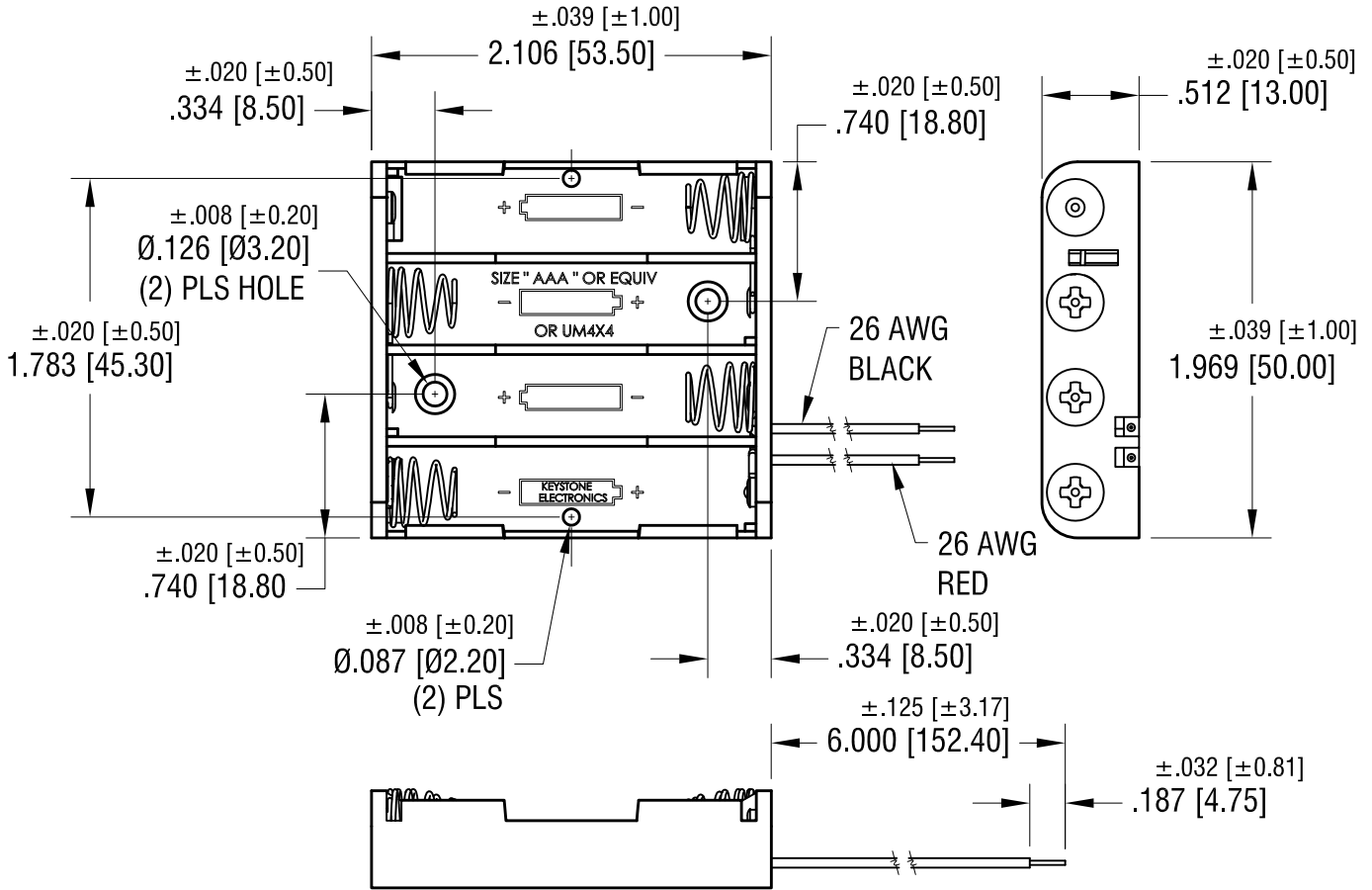
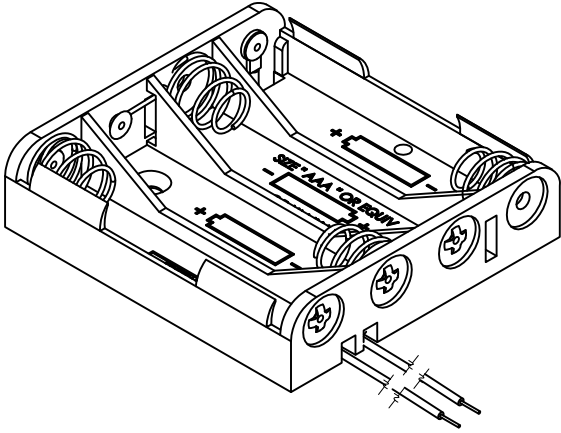

NOTE:

1. HOLDER: MAT'L: POLYPROPYLENE
2. SPRING: MAT'L: MUSIC WIRE, .024 [0.60] DIA. FINISH: NICKEL PLATE

DATE	DESCRIPTION	REV.
10.24.18	CHANGE AS PER ECN 18-044	C
1.16.07	CHANGE AS PER ECN 07-003	B
11.15.99	CHANGE AS PER ECN 99-087	A

KEYSTONE ELECTRONICS CORP.			
www.keyelco.com • NEW HYDE PARK, NY 11040 • Tel (516) 328-7500			
PART NAME		BATTERY HOLDER (4) 'AAA'	
MATERIAL		AS NOTED	
FINISH	AS NOTED	DRN BY	BOONE
		APP'D	LN
		DATE	6.09.99
		SCALE	1X
TOLERANCES	INCH [MM]	CODE	DWG NO.
DECIMAL	$\pm .015$ [± 0.38]	C	2482
ANGULAR	$\pm 1^\circ$		
UNLESS OTHERWISE SPECIFIED			