

DATE	DESCRIPTION	REV.
9.17.04	CHANGE AS PER ECN 04-105	E
11.04.11	CHANGE AS PER ECN 11-148	F

**MOUNTING DETAIL**

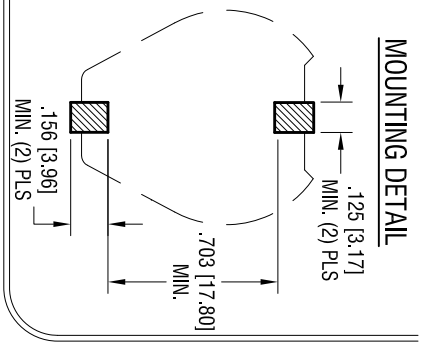

**SECTION A-A**

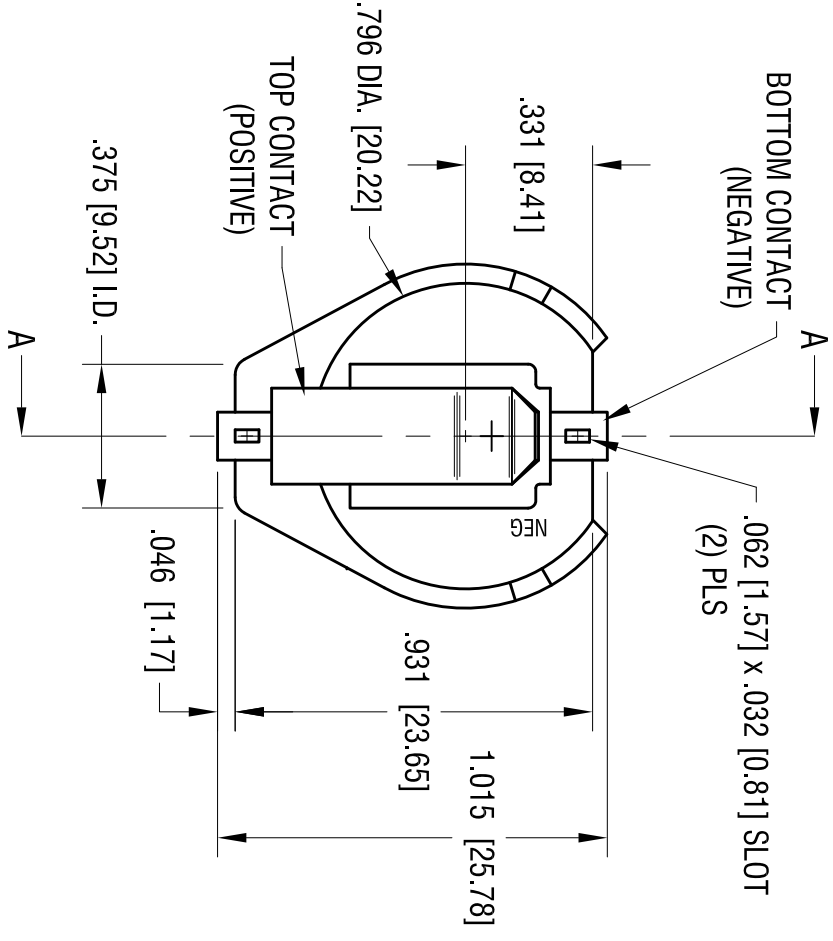
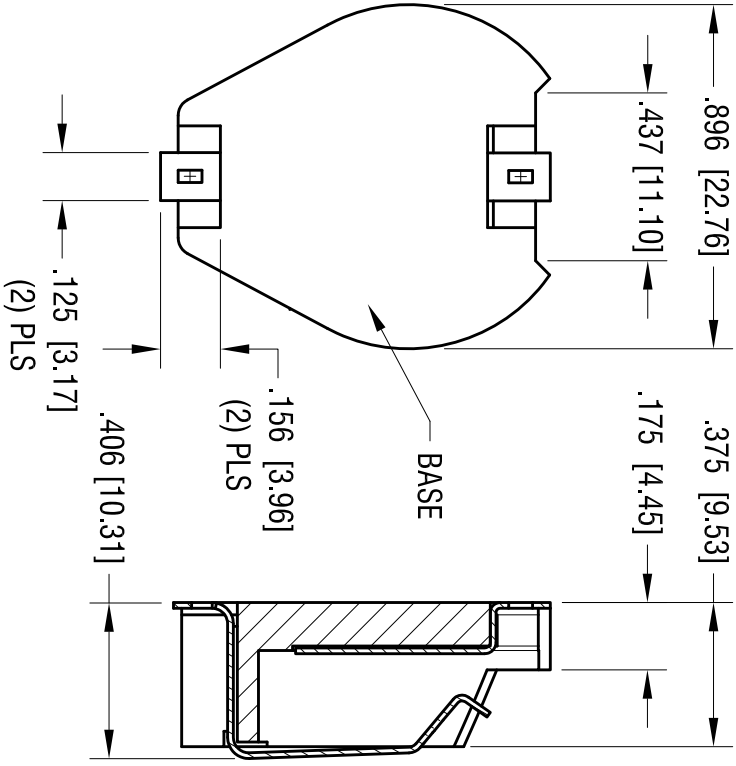

- NOTES:**
1. BASE:  
MATERIAL - HIGH TEMPERATURE NYLON (UL 94V-0)

2. CONTACTS (TOP AND BOTTOM):  
COLOR BLACK  
MATERIAL - .015 [0.38] THK SPRING STEEL  
FINISH: TIN NICKEL PLATE

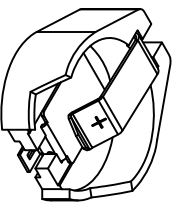

**ACTUAL SIZE**

**KEYSTONE ELECTRONICS CORP.**  
 www.keystec.com • NEW HYDE PARK, NY 11040 • Tel (516) 328-7500

**PART NAME**  
 DUAL 20mm BATTERY HOLDER, SMT

**MATERIAL**  
 AS NOTED

**FINISH**  
 AS NOTED

TOLERANCES	INCH	[MM]	CODE	DRN BY	DATE
DECIMAL	± .010	[± 0.25]	C	NT	12.14.92
ANGULAR	± 1°			LN	SCALE 2X

**DWG NO.**  
 1062

THIS DOCUMENT IS THE PROPERTY OF KEYSTONE ELECTRONICS CORP. AND SHALL NOT BE REPRODUCED, DISTRIBUTED OR USED AS A BASIS FOR MANUFACTURE WITHOUT PRIOR WRITTEN PERMISSION FROM KEYSTONE ELECTRONICS CORP.