

MOUNTING DETAIL

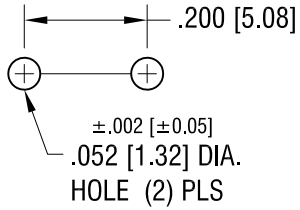

THIS DOCUMENT IS THE PROPERTY OF KEYSTONE ELECTRONICS CORP. AND SHALL NOT BE REPRODUCED, DISTRIBUTED OR USED AS A BASIS FOR MANUFACTURE WITHOUT PRIOR WRITTEN PERMISSION FROM KEYSTONE ELECTRONICS CORP.

ACTUAL SIZE

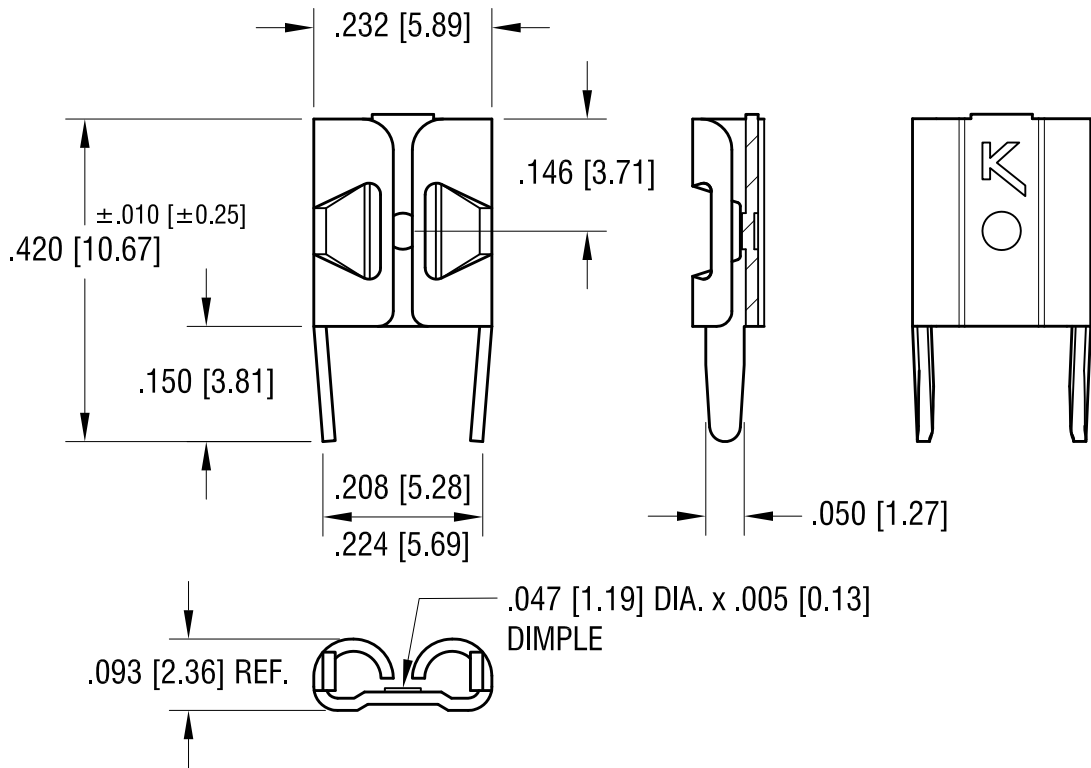

11.25.19	CHANGE AS PER ECN 19-089	L
5.01.19	CHANGE AS PER ECN 19-046	K
12.05.13	CHANGE AS PER ECN 13-110	I
9.10.12	CHANGE AS PER ECN 12-135	H
2.28.08	CHANGE AS PER ECN 08-092	G
DATE	DESCRIPTION	REV.

KEYSTONE ELECTRONICS CORP.			
www.keyelco.com • NEW HYDE PARK, NY 11040 • Tel (516) 328-7500			
PART NAME .187 x .020 PC QUICK-FIT TERMINAL			
MATERIAL .016 [0.40] TH'K BRASS			
FINISH TIN NICKEL PLATE		DRN BY BOONE	DATE 1.20.95
		APP'D LN	SCALE 4X
TOLERANCES	INCH [MM]	CODE	DWG NO.
DECIMAL	± .005 [± 0.13]	C	3548
ANGULAR	± 1°		
UNLESS OTHERWISE SPECIFIED			