

PCB Support - Push Spacer - High Temperature - Nylon 66 - BLACK

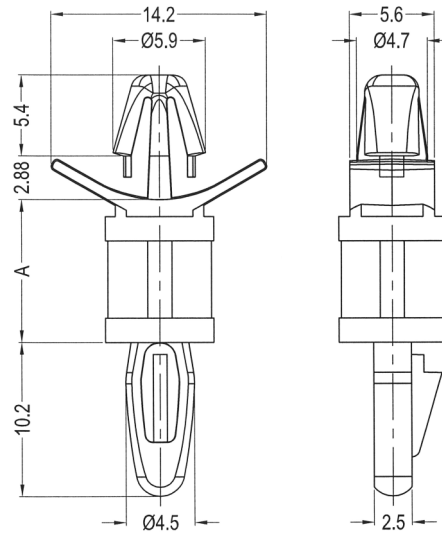

Part No.	A (mm)	PCB Panel Thickness (mm)	PCB Mounting Hole (mm)	Chassis Panel Thickness (mm)	Chassis Mounting Hole (mm)
10197	25.4	0.79 - 1.98	4.75	1.57	4