

## PCB Support - Mini - Flame Retardant - UL94V-0 Nylon - NATURAL

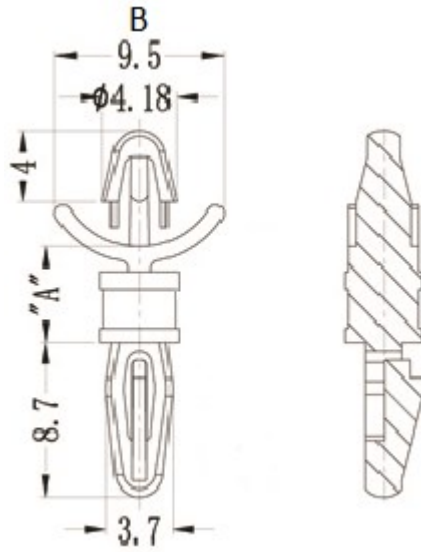

Part No.	A (mm)	Panel Thickness (mm)	PCB Hole Size	Chassis Hole Size	B (mm)
10189	6.4	1.57	3.18	3.18	9.5