

## PCB Support - Threaded - Female - Flame Retardant - UL94V-0 Nylon - NATURAL

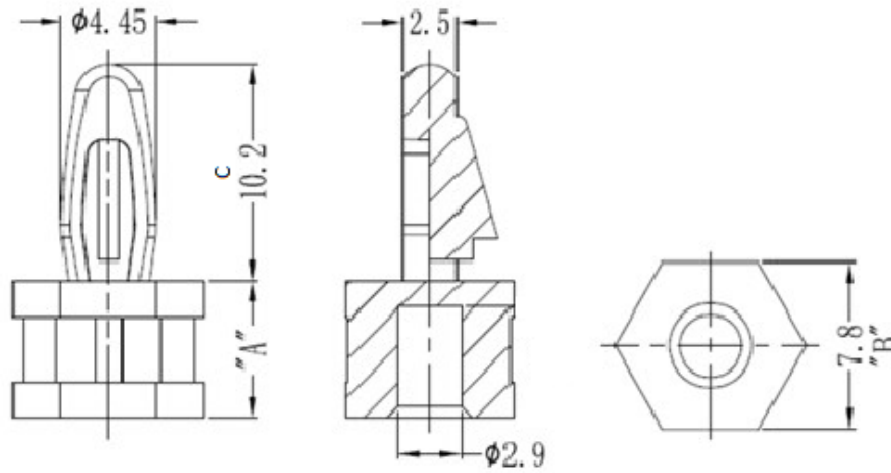

Part No.	A (mm)	Panel Thickness (mm)	Top Hole Diameter (mm)	Thread Size	B (mm)	C (mm)
10187	12.7	1.57	4	#6-32	7.8	10.2