

THIS DOCUMENT IS THE PROPERTY OF KEYSTONE ELECTRONICS CORP. AND SHALL NOT BE REPRODUCED, DISTRIBUTED OR USED AS A BASIS FOR MANUFACTURE WITHOUT PRIOR WRITTEN PERMISSION FROM KEYSTONE ELECTRONICS CORP.

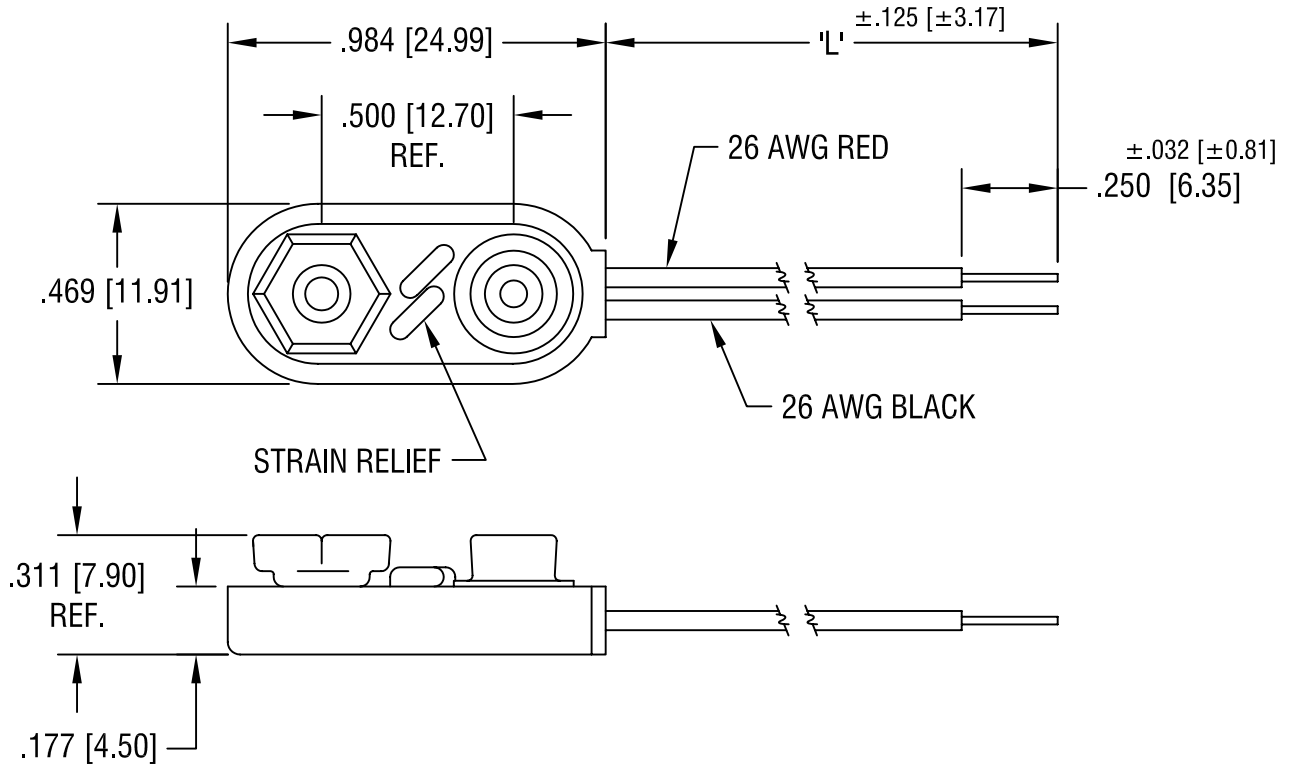

NOTE:

1. MAT'L:
 WIRE: 26 AWG, 1007 UL/CSA APPROVED
 CONTACTS: BRASS, NICKEL PLATE
 COVER: MOLDED ABS
2. RED WIRE CONNECTED TO FEMALE CONTACT;
 BLACK WIRE CONNECTED TO MALE CONTACT.

PART NO.	'L' DIM.
232-M	4.000 [101.60]
233-M	6.000 [152.40]
234-M	8.000 [203.20]

KEYSTONE ELECTRONICS CORP.

ASTORIA, N.Y. 11105-2017

PART NAME			
MOLDED ECONOMY '9' VOLT BATTERY STRAP			
MATERIAL			
AS NOTED			
FINISH		DRN BY	DATE
AS NOTED		BOONE	11.11.05
		APP'D	SCALE
			2X
TOLERANCES	INCH [MM]	CODE	DWG NO.
DECIMAL	± .020 [± 0.50]	C/M	232-M - 234-M
ANGULAR	± 1°		
UNLESS OTHERWISE SPECIFIED			

DATE	DESCRIPTION	REV.