

DATE	DESCRIPTION	REV.
9.16.15	CHANGE AS PER ECN 15-097 BASE MAT'L WAS PBT (BLACK)	A

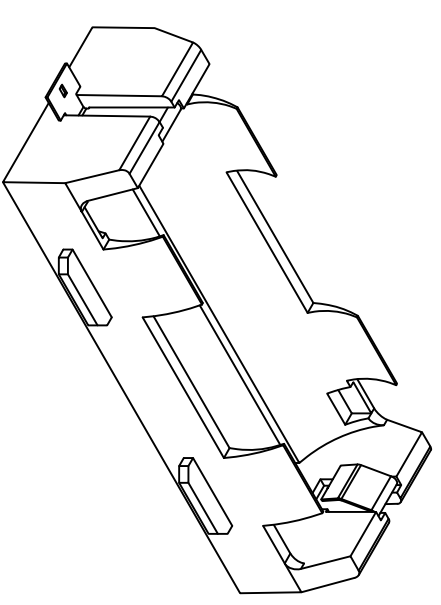
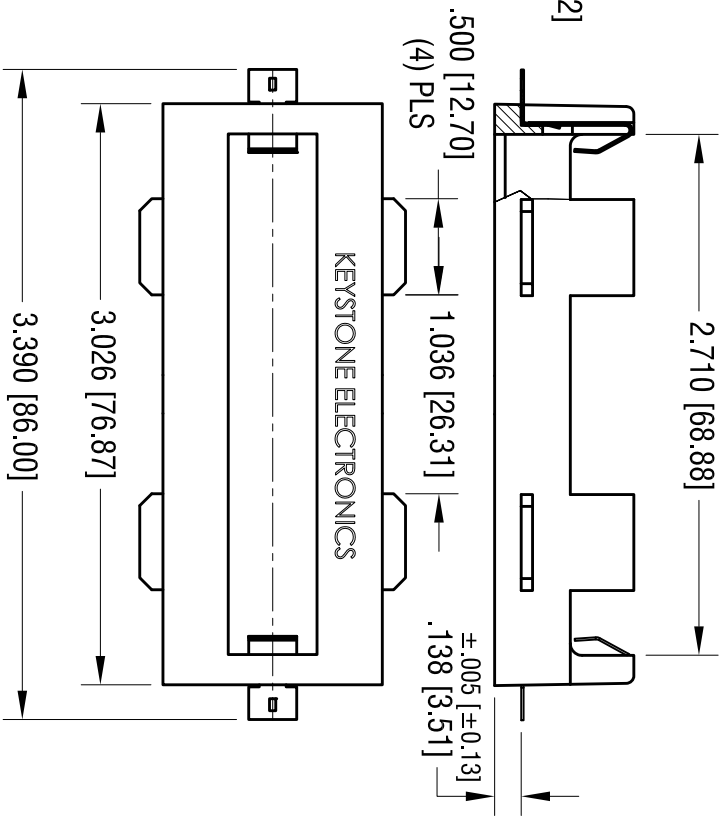
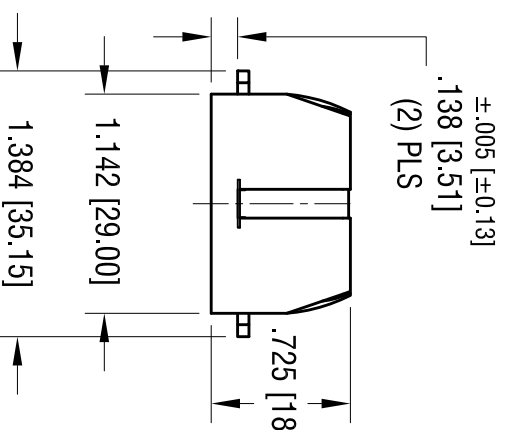
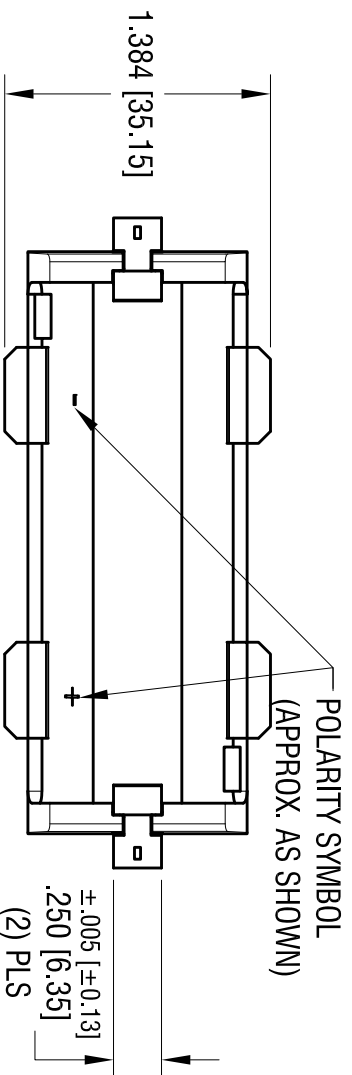

- NOTE:
1. BASE:  
MAT'L: STANYL (BLACK COLOR)
  2. CONTACT:  
MAT'L: .012 THK STAINLESS STEEL  
FINISH: GOLD FLASH, OVER NICKEL PLATE

THIS DOCUMENT IS THE PROPERTY OF KEYSTONE ELECTRONICS CORP. AND SHALL NOT BE REPRODUCED, DISTRIBUTED OR USED AS A BASIS FOR MANUFACTURE WITHOUT PRIOR WRITTEN PERMISSION FROM KEYSTONE ELECTRONICS CORP.

<b>KEYSTONE ELECTRONICS CORP.</b>			
www.keystec.com • ASTORIA, N.Y. 11105-2017 • Tel (718) 956-8900			
PART NAME: PC BATTERY HOLDER, 26650			
MATERIAL: AS NOTED			
FINISH: AS NOTED		DRN BY: NT	DATE: 11.07.14
TOLERANCES	INCH [MM]	CODE	DWG NO.
DECIMAL	$\pm .010$ [ $\pm 0.25$ ]	C	1106
ANGULAR	$\pm 1^\circ$		
		App'D: RH	SCALE: 1X