

THIS DOCUMENT IS THE PROPERTY OF
KEYSTONE ELECTRONICS CORP. AND
SHALL NOT BE REPRODUCED, DISTRIBUTED
OR USED AS A BASIS FOR MANUFACTURE
WITHOUT PRIOR WRITTEN PERMISSION
FROM KEYSTONE ELECTRONICS CORP.

ACTUAL SIZE

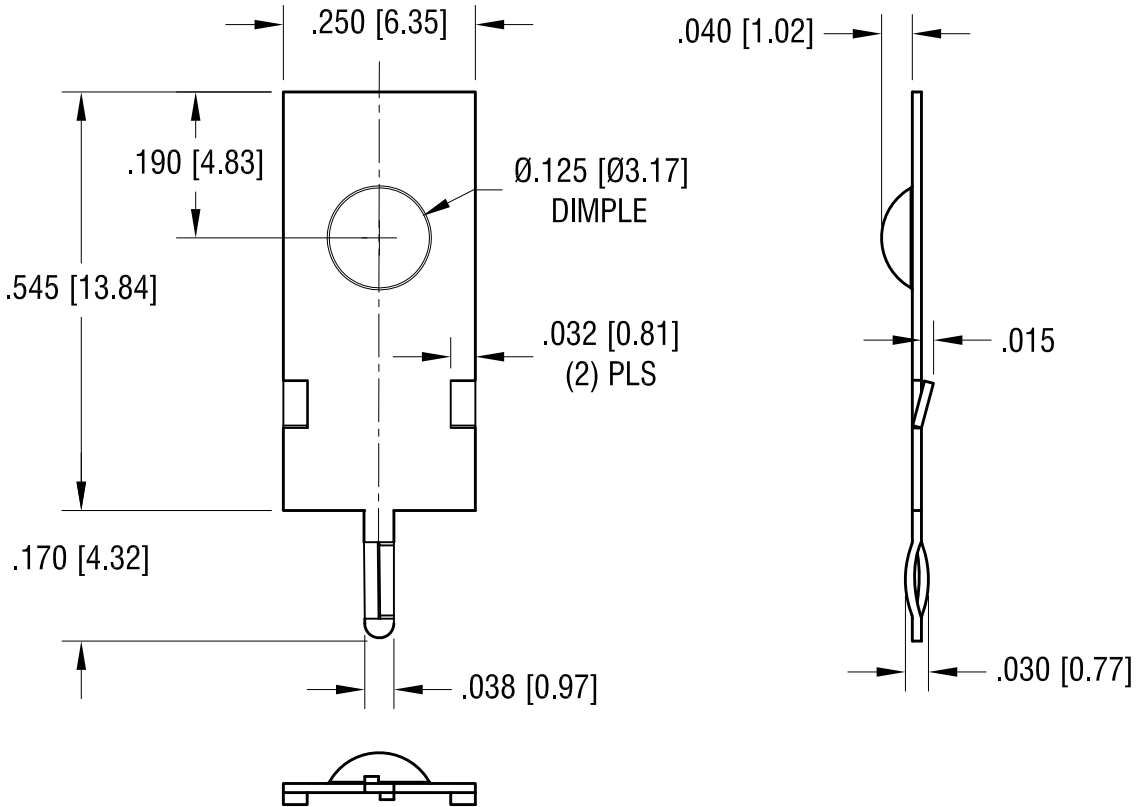

NOTE:

1. PART MUST BE FREE OF ALL BURRS AND SHARP EDGES.

KEYSTONE ELECTRONICS CORP.

www.keyelco.com • ASTORIA, N.Y. 11105-2017 • Tel (718) 956-8900

PART NAME

THM BATTERY CONTACT

MATERIAL

.012 [0.30] TH'K STAINLESS STEEL

FINISH

TIN NICKEL PLATE

DRN BY

NT

DATE

5.19.14

APP'D

LN

SCALE

4X

TOLERANCES

INCH [MM]

DECIMAL $\pm .005 [\pm 0.13]$

ANGULAR $\pm 1^\circ$

UNLESS OTHERWISE SPECIFIED

CODE

C

DWG NO.

1011-1

DATE

DESCRIPTION

REV.