

THIS DOCUMENT IS THE PROPERTY OF
KEYSTONE ELECTRONICS CORP. AND
SHALL NOT BE REPRODUCED, DISTRIBUTED
OR USED AS A BASIS FOR MANUFACTURE
WITHOUT PRIOR WRITTEN PERMISSION
FROM KEYSTONE ELECTRONICS CORP.

ACTUAL SIZE

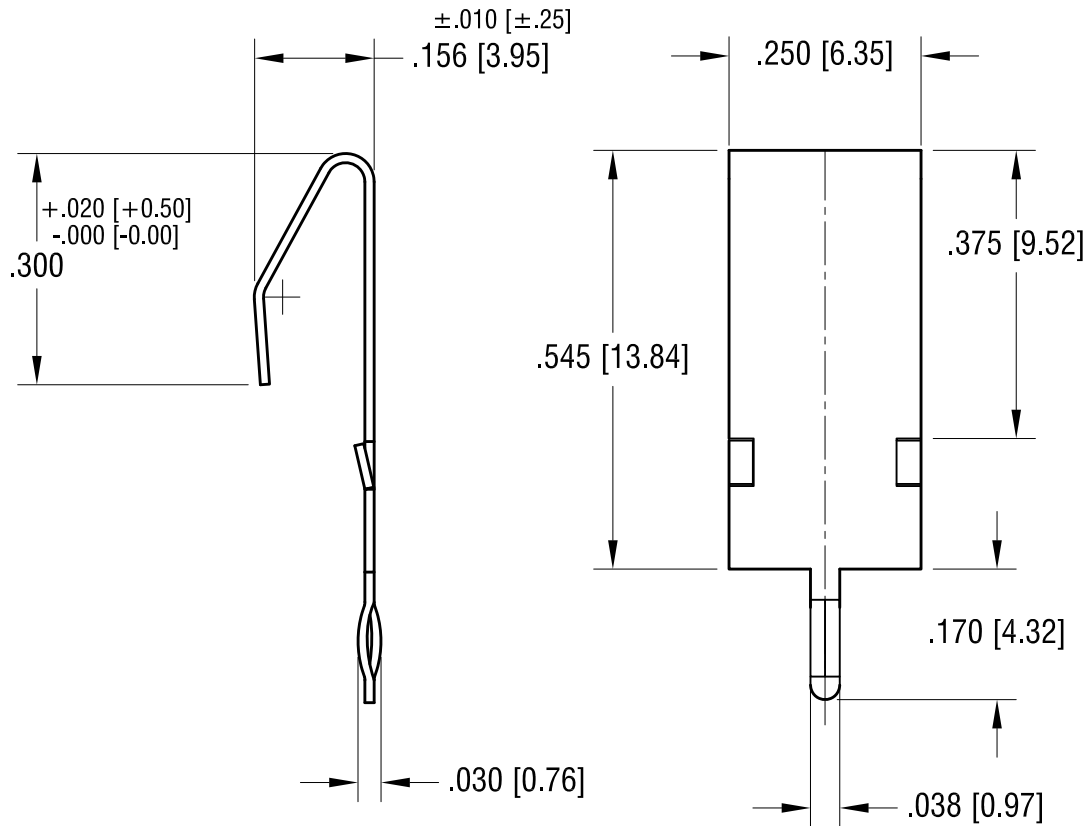

NOTE:

1. MOUNTING HOLE 0.47 [1.20] DIA.

KEYSTONE ELECTRONICS CORP.

www.keyelco.com • NEW HYDE PARK, NY 11040 • Tel (516) 328-7500

PART NAME

THM BATTERY CONTACT

MATERIAL

.012 [0.30] TH'K STAINLESS STEEL

FINISH

TIN NICKEL PLATE

DRN BY

NT

DATE

1.06.11

APP'D

RH

SCALE

4X

TOLERANCES

INCH [MM]

DECIMAL

$\pm .005$ [± 0.13]

ANGULAR

$\pm 1^\circ$

UNLESS OTHERWISE SPECIFIED

CODE

C

DWG NO.

1017-1

9.08.15	CHANGE AS PER ECN 15-088	B
10.10.13	CHANGE AS PER ECN 13-097	A
DATE	DESCRIPTION	REV.