

THIS DOCUMENT IS THE PROPERTY OF
KEYSTONE ELECTRONICS CORP. AND
SHALL NOT BE REPRODUCED, DISTRIBUTED
OR USED AS A BASIS FOR MANUFACTURE
WITHOUT PRIOR WRITTEN PERMISSION
FROM KEYSTONE ELECTRONICS CORP.

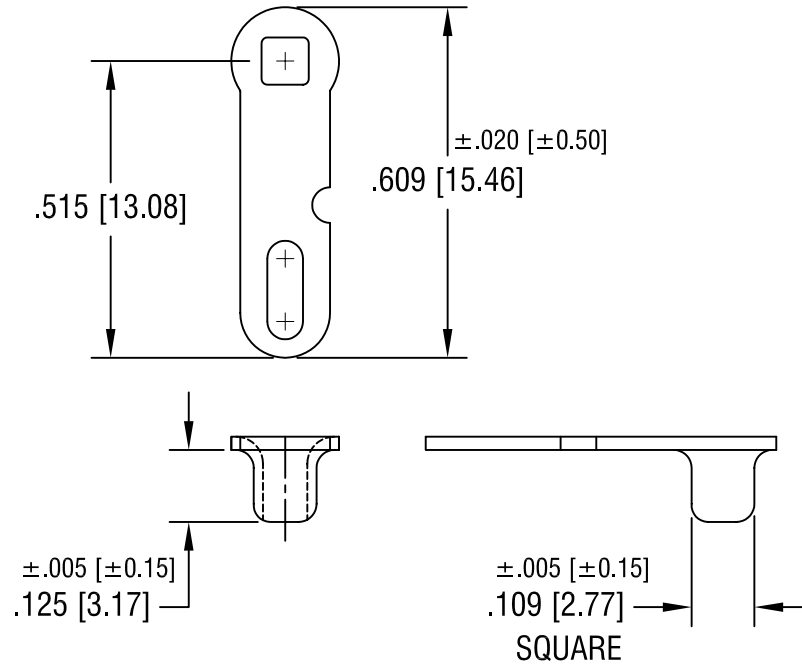

KEYSTONE ELECTRONICS CORP.			
ASTORIA, N.Y. 11105-2017			
PART NAME		SOLDER TERMINAL	
MATERIAL		.023 [0.58] TH'K BRASS	
FINISH		DRN BY	DATE
TIN PLATE		BOONE	4.13.82
		APPD	SCALE
		LN	3X
11.29.04	CHANGE AS PER ECN 04-157	B	
3.7.96	CHANGE AS PER ECR 96-008	A	
DATE	DESCRIPTION	REV.	DWG NO.
			1204
TOLERANCES		INCH	[MM]
DECIMAL		$\pm .010$	$[\pm 0.25]$
ANGULAR		$\pm 1^\circ$	
UNLESS OTHERWISE SPECIFIED		CODE	
		C/M	