

THIS DOCUMENT IS THE PROPERTY OF  
KEYSTONE ELECTRONICS CORP. AND  
SHALL NOT BE REPRODUCED, DISTRIBUTED  
OR USED AS A BASIS FOR MANUFACTURE  
WITHOUT PRIOR WRITTEN PERMISSION  
FROM KEYSTONE ELECTRONICS CORP.

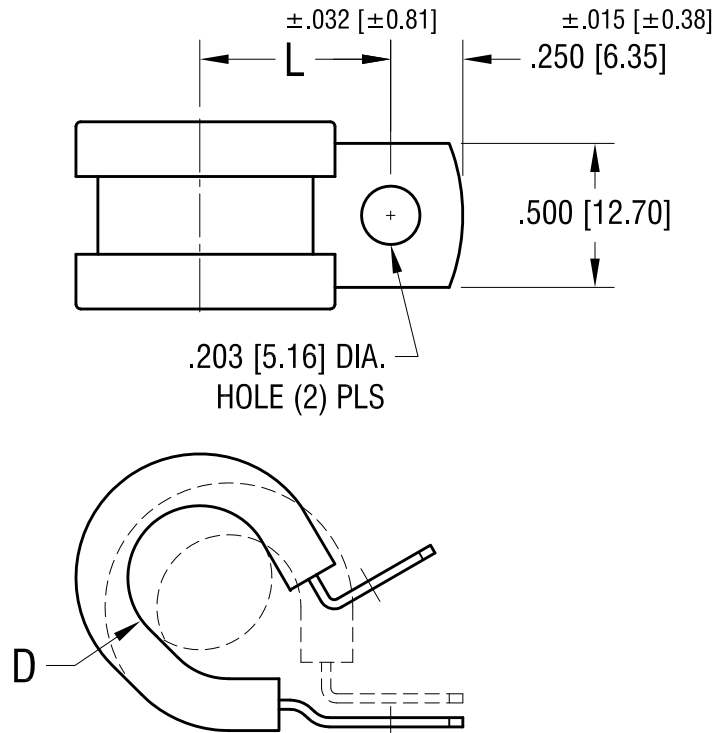

$\pm .032$ [ $\pm 0.81$ ] 'L' DIM.	$\pm .032$ [ $\pm 0.81$ ] 'D' FOR DIA.
.718 [18.20]	.625 [15.90]

<b>KEYSTONE ELECTRONICS CORP.</b>			
www.keyelco.com • NEW HYDE PARK, NY 11040 • Tel (516) 328-7500			
PART NAME			
CUSHIONED CABLE CLAMP			
MATERIAL			
.032 [.81]TH'K STAINLESS STEEL, EPDM RUBBER			
FINISH		DRN BY	DATE
-		BOONE	12.04.06
		APP'D	SCALE
		LN	X
TOLERANCES	INCH [MM]	CODE	DWG NO.
DECIMAL	$\pm .010$ [ $\pm 0.25$ ]	C	8093
ANGULAR	$\pm 1^\circ$		
UNLESS OTHERWISE SPECIFIED			

DATE	DESCRIPTION	REV.
------	-------------	------