

THIS DOCUMENT IS THE PROPERTY OF
KEYSTONE ELECTRONICS CORP. AND
SHALL NOT BE REPRODUCED, DISTRIBUTED
OR USED AS A BASIS FOR MANUFACTURE
WITHOUT PRIOR WRITTEN PERMISSION
FROM KEYSTONE ELECTRONICS CORP.

ACTUAL SIZE

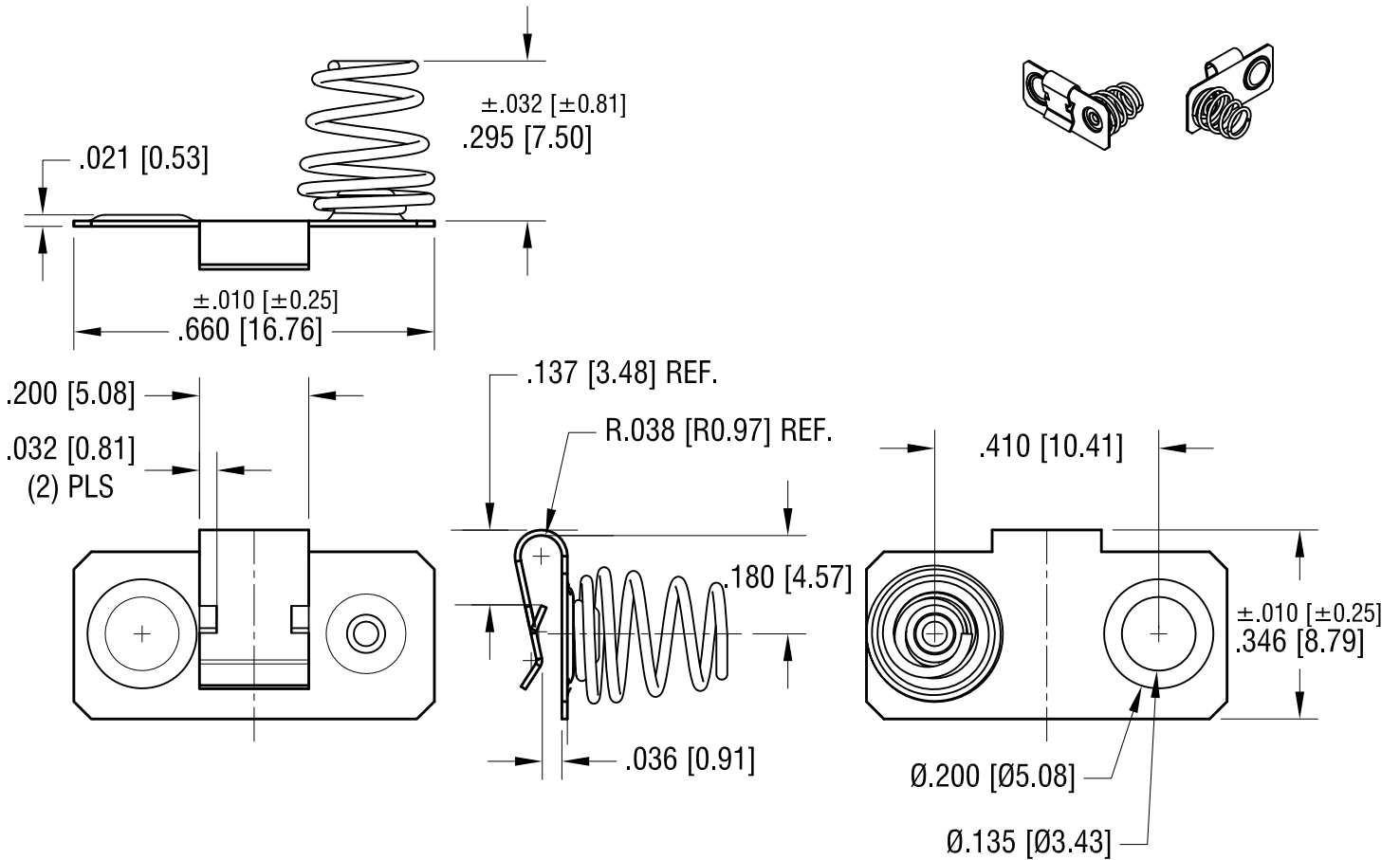

1. BASE:
MAT'L - .010 [0.25] TH'K SPRING STEEL
2. SPRING CONTACT:
MAT'L - .020 [0.50] DIA. MUSIC WIRE
3. SPRING EYELETED TO BASE

KEYSTONE ELECTRONICS CORP.			
www.keyelco.com • NEW HYDE PARK, NY 11040 • Tel (516) 328-7500			
PART NAME			
DUAL SPRING CONTACT, 'AAA' - 'AAAA'			
MATERIAL			
AS NOTED			
FINISH		DRN BY	DATE
NICKEL PLATE		NT	10.25.17
		APP'D	SCALE
		LN	3X
10.16.18	CHANGE AS PER ECN 18-041	A	
DATE	DESCRIPTION	REV.	
TOLERANCES INCH [MM]		CODE	DWG NO.
DECIMAL ± .005 [± 0.13]		C	
ANGULAR ± 1°			
UNLESS OTHERWISE SPECIFIED			
			299